

W. WEITLING.
Sewing Machine.

3 Sheets—Sheet 1.

No. 72,574.

Patented Dec. 24, 1867.

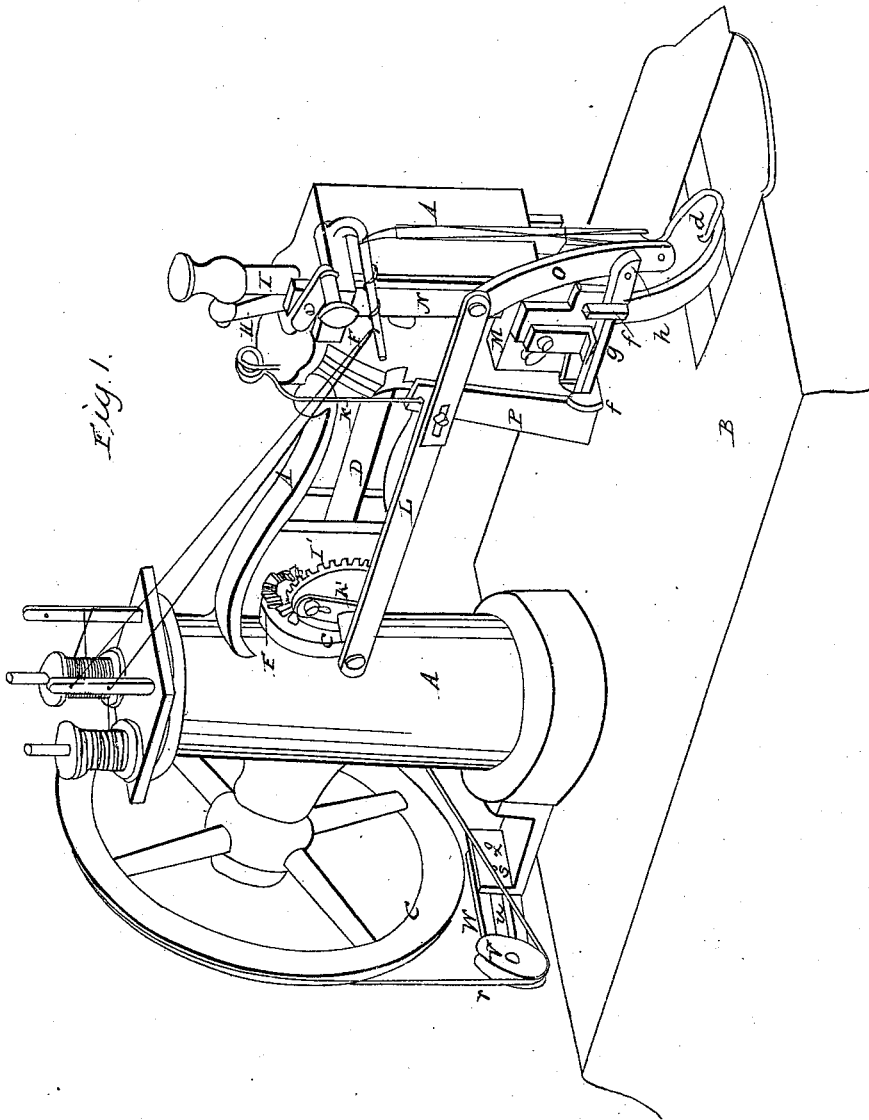

Fig. 1.

Attest.
Chas. N. Hebborn
William Adams.

Inventor
Wm. Weitling
by his atty
Gustave & Cohen

W. WEITLING.
Sewing Machine.

No. 72,574.

Patented Dec. 24, 1867.

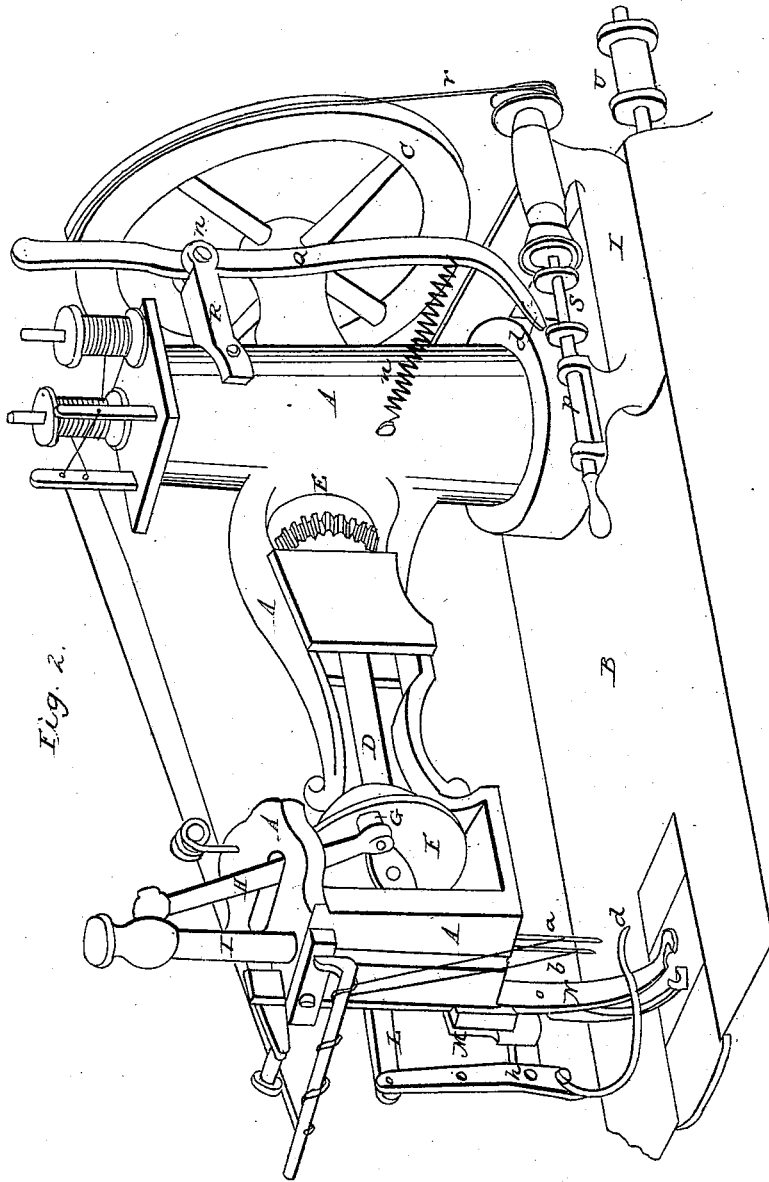

Fig. 2.

Attest
A. W. Hibbard
William A. Kay.

Inventor.
Wm Weitling
by his attys.
Anthony & Cocheny

W. WEITLING.
Sewing Machine.

No. 72,574.

Patented Dec. 24, 1867.

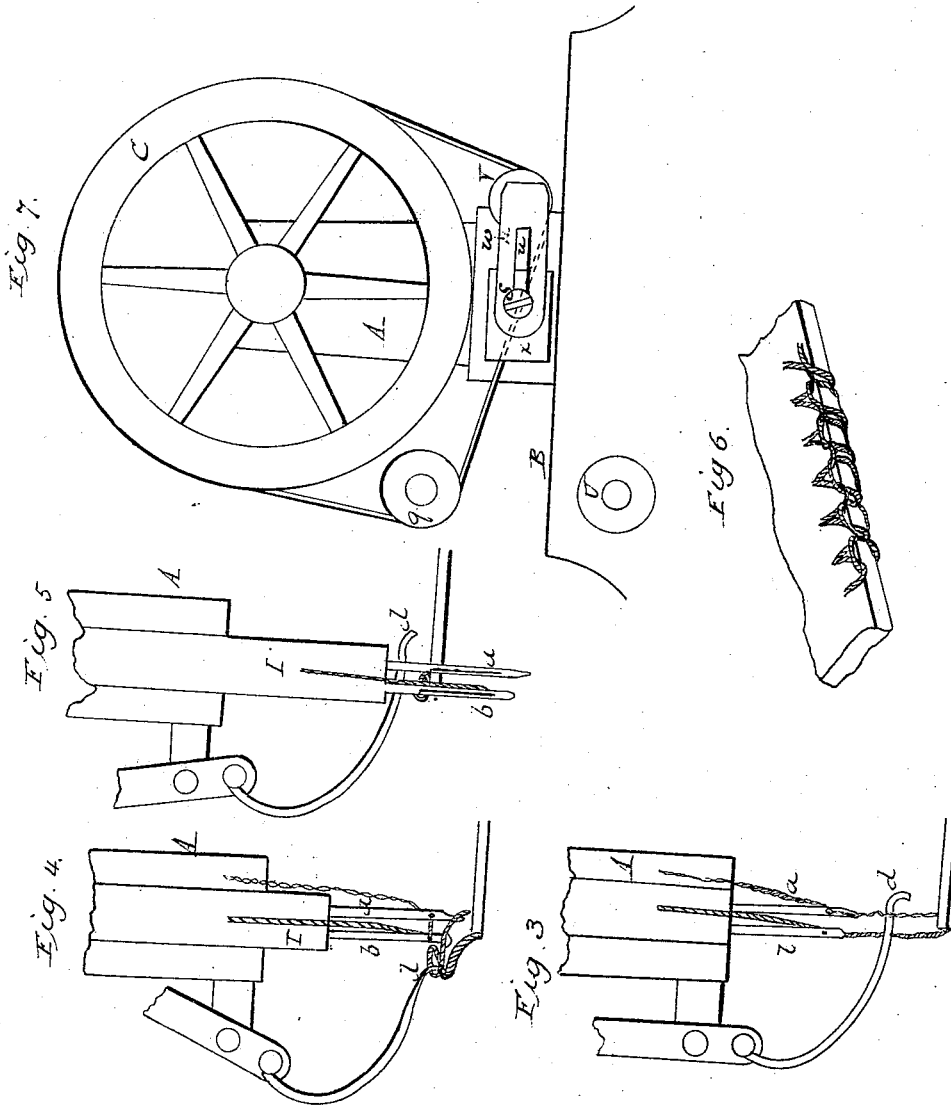

Attest
St. W. Alban
William Mayo

Inventor.
Wm Weitling
 by his attys
Gregory & Cohen

United States Patent Office.

WILLIAM WEITLING, OF NEW YORK, N. Y.

Letters Patent No. 72,574, dated December 24, 1867.

IMPROVEMENT IN SEWING-MACHINES.

The Schedule referred to in these Letters Patent and making part of the same.

TO ALL WHOM IT MAY CONCERN:

Be it known that I, WILLIAM WEITLING, of the city and county of New York, and State of New York, have invented certain new and useful Improvements in Sewing-Machines; and I do hereby declare that the following is a full, clear, and exact description of the construction and operation of the same, reference being had to the accompanying drawings, in which—

Figure 1 represents a perspective view of my sewing-machine.

Figure 2 represents a similar view reversed.

Figures 3, 4, 5, represent different positions of the needle, thread-carrier, and hook, showing the operation of the same.

Figure 6 represents a perspective view of the upper side and edge of the stitch made by the machine when used for button-hole work or for edging.

Figure 7 represents a rear view of the parts which constitute my device for winding the thread upon the shuttle-spool.

To enable others skilled in the art to make and use my invention, I will proceed to describe its construction and operation.

A represents the frame of the machine; B represents the platform, and C the driving-wheel, whose shaft, D, communicates motion to the bevel-wheel E and cam-plate F. The crank-pin G is secured to the face of the cam-plate F, and, by means of the pitman H, communicates motion to the needle-bar I, to which the pointed needle *a*, and a blunt thread-carrier, *b*, are secured, as shown on the drawings. The needle *a* pierces the cloth in the ordinary manner, while the thread-carrier *b* passes along the edge of the cloth, or through the slit of the button-hole, and when they begin to rise, the shuttle underneath the platform passes through the loops of both the thread-carrier and needle, in a manner hereafter fully to be described, interlacing the two threads by the action of the looper, and thus a stitch is made suitable for edging or button-hole work. I' represents a bevel-wheel, which is operated by the bevel-wheel E, and which has an adjustable crank-arm, K, secured to its outer face, whose crank-pin, *c*, operates the connecting-rod L, which latter operates the looper-hook *d*. The frame M, to which the looper *d* is attached, may either be permanently secured to the frame A of the machine, or it may be secured to the foot-bar N, so that it can be raised or lowered with the same. Said frame M is provided with two lugs *f*, which serve as bearings to the rock-shaft *g*, and to one end of which the lever or shank O of the looper *d* is pivoted at *h*, while its other end is provided with a toe or plate, P, whose end is pressed against the circumference of the cam F, by the action of the spring *k*, and the plate P is thus acted upon by the cam at certain intervals. The looper *d* thus receives a compound motion, one resulting from the action of the bevel-wheel I, and causing the looper to turn on its pivot *h*, and the other resulting from the action of the cam F, and resulting in the swinging of the looper *d* on its rock-shaft *g*, both motions thus resulting in a compound motion of the hook *d*, which, at each stroke of the needle, describes a curve around the lower part of the thread-carrier *b*, the hook taking the thread of the needle *a* from under it and laying it in loop-form under the thread-carrier *b*, which passes through this loop and through the slit in the button-hole.

In the drawings, I have shown the needle-thread in red, and the thread of the thread-carrier in blue lines. When the needle and thread-carrier are at their highest ascending point, as shown at fig. 3, the position of the hook *d* is as represented in said figure. When the needle and thread-carrier begin to descend, hook *d* catches the threads from under the needles, and carries them forward and around the lower part of the thread-carrier, as represented at fig. 4. The thread of the thread-carrier *b* is by this operation drawn aside to clear the way for the passage of the thread-carrier. When the needle and thread-carrier have arrived at their lowest point, the shuttle and its thread pass through the loops of both the upper threads, as follows: The thread of the needle closes in loop-form around the thread-carrier, as represented at fig. 5, holding the thread of the thread-carrier in its groove, and aiding thus in securing the formation of the loop on the lower face of the cloth, as the needle and carrier commence to rise for the passage of the shuttle, which loop in the thread of the piercing-needle *a* is created by the closing of the fabric around the threads and needle at the period of its rising. The needle and thread-carrier then ascend again to their highest position, and the operation is repeated. In this operation, a button-hole or edging-stitch is obtained by the interlooping of the thread of the needle with that of the

thread-carrier on the upper side of the edge or button-hole, and by the interlooping of both of these threads with that of the shuttle on the lower side of the button-hole, and which results in a stitch, the upper side of which is represented in a perspective view at fig. 6.

My machine may be provided with two looper-hooks, *d*, bent in opposite directions, and by properly adjusting and shaping the cam *F*, either of the hooks may be used, and the thread of the needle may be laid in loop-form under the thread-carrier, or the thread of the thread-carrier under that of the needle.

In sewing-machines in which a shuttle in any form is used, the thread must be wound up upon the shuttle-spool. This is a tedious operation, and I have devised a mechanism by which said winding is effected automatically by the sewing-machine while in operation, without interrupting the work thereof. This winding-apparatus is constructed as follows:

A lever, *Q*, is pivoted at *m*, to the bracket *R* of the frame *A*, and its upper end is pressed against the face of either the treadle or the driving-wheel *C*, by the action of the spring *n*. The face of the treadle or driving-wheel is cam-shaped, and when it turns, it causes the lower eye-pointed end of the lever *Q* to vibrate over the entire length of the shuttle-bobbin *S*, which is set right opposite to it. The bobbin-shuttle is set into a chuck, *o*, which is supported by the frame *T* attached to the platform *B*, and its end is supported by the point of the screw-shaft *p*, in a similar manner as an article to be turned is set into a lathe. The chuck *o* is revolved by means of a pulley, *g*, over which a cord or belt, *r*, passes to the circumference of the treadle or driving-wheel *C*, and the thread from the bobbin *U* is passed through the eye *t* of the lever *Q*, which, when the machine is in operation, will lay it smoothly and with great regularity over the bobbin-shuttle, and when the latter is full it can be removed by loosening the screw *p*. To regulate the tension of the belt or cord *r*, I use a guide-pulley, *V*, which is supported on an adjustable arm, *W*, which is fastened to the bracket *X* by means of a screw, *s*, which latter passes through a slot *u*, and by adjusting the position of the pulley *V*, the belt *r* can be tightened or slackened at pleasure.

Having thus fully described the nature of my invention, what I claim herein as new, and desire to secure by Letters Patent, is—

- 1 The combination of a hook-pointed lever, with the thread-carrier, piercing-needle, and shuttle of a sewing-machine, and operating substantially as and for the purposes described.
2. The application to sewing-machines of a thread-winding apparatus, constructed and operated as described.
3. Giving motion to the thread-leading lever of a winding-apparatus attached to a sewing-machine, by making the rim of the driving-wheel cam-shaped to operate said lever, substantially in the manner and for the purposes set forth.
4. In combination with the thread-winding device herein described, I claim the adjustable guide-pulley *V*, for adjusting the tension of the cord *r*, by which the thread-winding apparatus is operated, substantially in the manner herein described.

WILLIAM WEITLING.

Witnesses:

CLEMENS MULLER,
HENRY ARENDS.